



Doc. version	0
Effective date	2004.02.05
Total pages	19

Product Specification

3.5" COLOR TFT-LCD MODULE

MODEL NAME: A035CN02 V2

- () Preliminary Specification
- () Final Specification

© 2004 AU Optronics
All Rights Reserved,

AUO hereby grant permission to
HP Imaging and Printing Group
(IPG) for making HP-IPG internal
use copies.

Note: The content of this
specification is subject to
change without prior notice.



Contents:

A. Physical specifications **P3**

B. Electrical specifications **P4**

 1. Pin assignment **P4**

 2. Absolute maximum ratings **P5**

 3. Electrical characteristics **P6**

 a. Typical operating conditions **P6**

 b. Current consumption **P6**

 4. AC Timing **P7**

 a. Timing conditions **P7**

 b. Timing diagram **P7**

C. Optical specifications **P8**

D. Reliability test items **P10**

E. Packing form **P11**

Appendix:

Fig.1 Outline dimension of TFT-LCD module **P12**

Fig.2 Sampling clock timing **P13**

Fig.3 Horizontal display timing range **P14**

Fig.4-(a) Horizontal timing **P15**

Fig.4-(b) Detail horizontal timing **P16**



Fig.5 Vertical shift clock timing. **P17**
Fig.6-(a) Vertical timing (From up to down).. **P18**
Fig.6-(b) Vertical timing (From down to up) **P19**

A. Physical specifications

NO.	Item	Specification	Remark
1	Display resolution (dot)	480(W)×234(H)	
2	Active area (mm)	72(W)×50.544(H)	
3	Screen size (inch)	3.5(Diagonal)	
4	Dot pitch (mm)	0.150(W)×0.216(H)	
5	Color configuration	R. G. B. delta	
6	Overall dimension (mm)	83(W)×60.5(H)×4.5(D)	Note 1
7	Weight (g)	TBD	

Note 1: Refer to Fig. 1.

B. Electrical specifications

1.Pin assignment

Pin No.	Symbol	I/O	Description	Remark
01	GND		Ground for logic circuit	
02	VCC		Supply voltage of logic control circuit for scan driver	
03	VGL	I	Negative power for scan driver	
04	VGH	I	Positive power for scan driver	
05	STVR	I/O	Vertical start pulse	
06	STVL	I/O	Vertical start pulse	
07	CKV	I	Shift clock input for scan driver	
08	U/D	I	Up/Down scan control input	
09	OEV	I	Output enable input for scan driver	
10	VCOM	I	Common electrode driving signal	
11	VCOM	I	Common electrode driving signal	
12	GLED1		LED module 1 Cathode	
13	VLED1		LED module 1 Anode	
14	VLED2		LED module 2 Anode	
15	GLED2		LED module 2 Cathode	
16	L/R	I	Left/Right scan control input	
17	Q1H	I	Analog signal rotate input	
18	OEH	I	Output enable input for data driver	
19	STHL	I/O	Start pulse for horizontal scan line	
20	STHR	I/O	Start pulse for horizontal scan line	
21	CPH3	I	Sampling and shifting clock pulse for data driver	
22	CPH2	I	Sampling and shifting clock pulse for data driver	
23	CPH1	I	Sampling and shifting clock pulse for data driver	
24	DVDD		Supply voltage of logic control for data driver	
25	DVSS		Ground for logic circuit	
26	VA	I	Alternated video signal input (Red)	
27	VB	I	Alternated video signal input (Green)	
28	VC	I	Alternated video signal input (Blue)	
29	AVDD		Supply voltage for analog circuit	
30	AVSS		Ground for analog circuit	

Note 1 : Selection of scanning mode

Setting of scan control input		IN/OUT state For start pulse				Scanning direction
U/D	L/R	STVR	STVL	STHR	STHL	
GND	V _{CC}	OUT	IN	OUT	IN	From up to down, and from left to right.
V _{CC}	GND	IN	OUT	IN	OUT	From down to up, and from right to left.
GND	GND	OUT	IN	IN	OUT	From up to down, and from right to left.
V _{CC}	V _{CC}	IN	OUT	OUT	IN	From down to up, and from left to right.

IN: Input; OUT: Output.

Note 2 : Definition of scanning direction. Refer to figure as below:

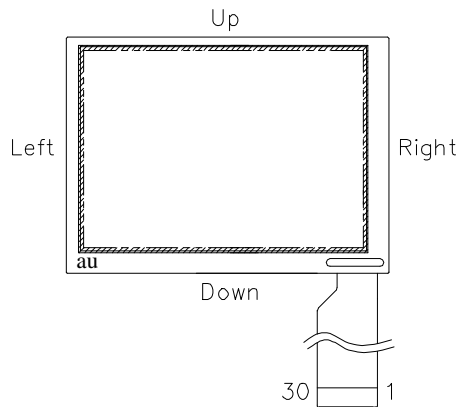

2. Absolute maximum ratings

Item	Symbol	Condition	Min.	Max.	Unit	Remark
Power voltage	V _{CC}	GND=0	-0.3	7	V	
	AV _{DD}	AV _{SS} =0	-0.3	7	V	
	V _{GH}	GND=0	-0.3	18	V	
	V _{GL}		-18	0.3	V	
	V _{GH} -V _{GL}		-	33	V	
Input signal voltage	V _i		-0.3	AV _{DD} +0.3	V	Note 1
	V _I		-0.3	V _{CC} +0.3	V	Note 2
	VCOM		-2.9	5.2	V	
Operating temperature	Topa		0	60	°C	Ambient temperature
Storage temperature	Tstg		-25	80	°C	Ambient temperature

Note 1: VR, VG, VB

Note 2: STHL, STHR, Q1H, OEH, L/R, CPH1~CPH3, STVR, STVL, OEV, CKV, U/D.

3. Electrical characteristics

a. Typical operating conditions (GND=AVss=0V, Note 5)

Item	Symbol	Min.	Typ.	Max.	Unit	Remark
Power supply	V _{CC}	3	5	5.2	V	
	AV _{DD}	4.8	5	5.2	V	
	V _{GH}	14.3	15	15.7	V	
	V _{GLAC}	3.5	5	7.5	Vp-p	AC component of V _{GL} . Note 1
	V _{GL-H}	-10	-9.5	-9	V	High level of V _{GL} .
Video signal Amplitude (VR, VG, VB)	V _{iA}	AV _{SS} +0.4	-	AV _{DD} -0.4	V	Note 2
	V _{iAC}	-	3	-	V	AC component
	V _{iDC}	-	AV _{DD} /2	-	V	DC component
VCOM	V _{CAC}	3.5	5	7.5	Vp-p	AC component, Note 3
	V _{CDC}	-	1.1	-	V	DC component
Input Signal voltage	H Level	V _{IH}	0.8V _{CC}	-	V _{CC}	Note 4
	L Level	V _{IL}	0	-	0.2V _{CC}	

Note 1: The same phase and amplitude with common electrode driving signal (VCOM).

Note 2: Refer to Fig.4- (a)

Note 3: The brightness of LCD panel could be adjusted by the adjustment of the AC component of VCOM.

Note 4: STHL, STHR, Q1H, OEH, L/R, CPH1~CPH3, STVR, STVL, OEV, CKV, U/D.

Note 5: Be sure to apply GND, V_{CC}, V_{GL} to the LCD first, and then apply V_{GH}.

b. Current consumption (GND=AVss=0V)

Parameter	Symbol	Condition	Min.	Typ.	Max.	Unit	Remark
Current for driver	I _{GH}	V _{GH} =15V	-	50	100	μA	
	I _{GL}	V _{GL-H} =-9.5V	-	-0.2	-0.6	mA	
	I _{CC}	V _{CC} =5V	-	1.5	4	mA	
	I _{DD}	AV _{DD} =5V	-	5	10	mA	

c. LED driving conditions

Parameter	Symbol	Min.	Typ.	Max.	Unit	Remark
LED current			20		mA	
LED voltage	V _L		(15)		V	1
LED Life Time	L _L	(10000)			Hr	Note 1,2

Note 1 : Ta. = 25°C, I_L = 20mA

The voltage (VL) is dependent on customer design for serial or parallel consideration of 8 LEDs.

Note 2 : Brightness to be decreased to 50% of the initial value.

4. AC Timing

a. Timing conditions

Parameter	Symbol	Min.	Typ.	Max.	Unit.	Remark
Rising time	t_r	-	-	10	ns	Note 1
Falling time	t_f	-	-	10	ns	Note 1
High and low level pulse width	t_{CPH}	299	308	319	ns	CPH1~CPH3
CPH pulse duty	t_{CWH}	40	50	60	%	CPH1~CPH3
CPH pulse delay	t_{C12} t_{C23} t_{C31}	70	$t_{CPH}/3$	$t_{CPH}/2$	ns	CPH1~CPH3
STH setup time	t_{SUH}	35	-	-	ns	STHR,STHL
STH hold time	t_{HDH}	35	-	-	ns	STHR,STHL
STH pulse width	t_{STH}	-	1	-	t_{CPH}	STHR,STHL
STH period	t_H	61.5	63.5	65.5	μs	STHR,STHL
OEH pulse width	t_{OEH}	-	3	-	t_{CPH}	OEH
Sample and hold disable time	t_{DIS1}	4	8.6	-	μs	
OEV pulse width	t_{OEV}	-	12	-	t_{CPH}	OEV
CKV pulse width	t_{CKV}	16	28	40	t_{CPH}	CKV
Clean enable time	t_{DIS2}	-	10	-	t_{CPH}	
Horizontal display start	t_{SH}	-	0	-	$t_{CPH}/3$	
Horizontal display timing range	t_{DH}	-	480	-	$t_{CPH}/3$	
STV setup time	t_{SUV}	400	-	-	ns	STVL,STVR
STV hold time	t_{HDV}	400	-	-	ns	STVL,STVR
STV pulse width	t_{STV}	-	-	1	t_H	STVL,STVR
Horizontal lines per field	t_V	256	262	268	t_H	
Vertical display start	t_{SV}	-	3	-	t_H	
Vertical display timing range	t_{DV}	-	234	-	t_H	
VCOM rising time	t_{rCOM}	-	-	3	μs	
VCOM falling time	t_{fCOM}	-	-	3	μs	
VCOM delay time	t_{DCOM}	-	-	3	μs	
RGB delay time	t_{DRGB}	-	-	1	μs	

Note 1: For all of the logic signals.

b. Timing diagram

Please refer to the attached drawings, from Fig.2 to Fig.6.

C. Optical specification (Note 1, Note 2, Note 3)

Item		Symbol	Condition	Min.	Typ.	Max.	Unit	Remark
Response time	Rise	Tr	$\theta = 0^\circ$	-	20	30	ms	Note 4, 6
	Fall	Tf		-	30	40	ms	
Contrast ratio		CR	At optimized viewing angle	100	150	-		Note 5, 6
Viewing angle	Top		$CR \geq 10$	10	-	-	deg.	Note 6, 7
	Bottom			30	-	-		
	Left			40	45	-		
	Right			40	45	-		
Brightness		Y_L	$\theta = 0^\circ$	200	250	-	nit	Note 8
White chromaticity shift	X	$\theta = 0^\circ$	0.25	0.3	0.35			
	y		0.3	0.35	0.4			

Note 1: Ambient temperature =25°C.

Note 2: To be measured in the dark room.

Note 3: To be measured at the center area of panel with a viewing cone of 1° by Topcon luminance meter BM-7, after 10 minutes operation.

Note 4: Definition of response time:

The output signals of photodetector are measured when the input signals are changed from "black" to "white"(falling time) and from "white" to "black"(rising time), respectively.

The response time is defined as the time interval between the 10% and 90% of amplitudes. Refer to figure as below.

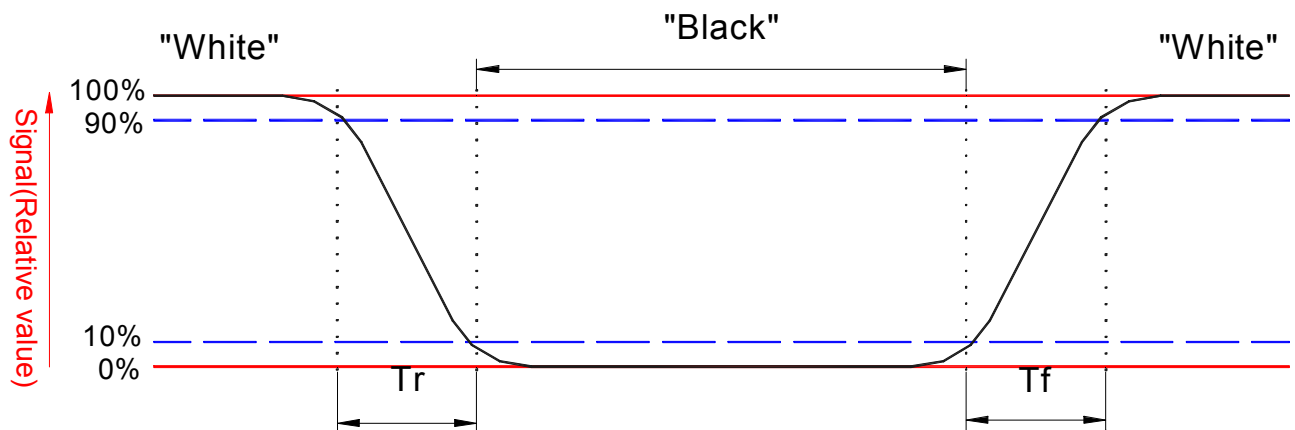

Note 5. Definition of contrast ratio:

Contrast ratio is calculated with the following formula.

$$\text{Contrast ratio (CR)} = \frac{\text{Photodetector output when LCD is at "White" state}}{\text{Photodetector output when LCD is at "Black" state}}$$

Note 6. White $V_i = V_{i50} \mp 1.5V$

Black $V_i = V_{i50} \pm 2.0V$

“±” means that the analog input signal swings in phase with COM signal.

“∓” means that the analog input signal swings out of phase with COM signal.

V_{i50} : The analog input voltage when transmission is 50%

The 100% transmission is defined as the transmission of LCD panel when all the input terminals of module are electrically opened.

Note 7. Definition of viewing angle: Refer to figure as below.

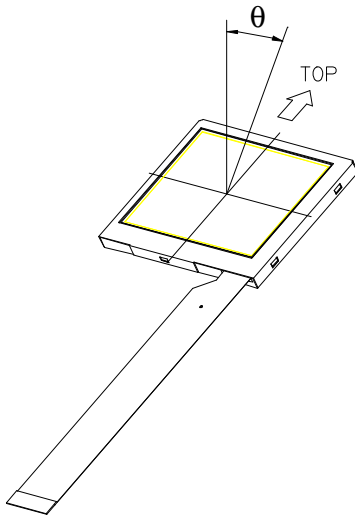

Note 8. Measured at the center area of the panel when all the input terminals of LCD panel are electrically opened.

E. Packing form

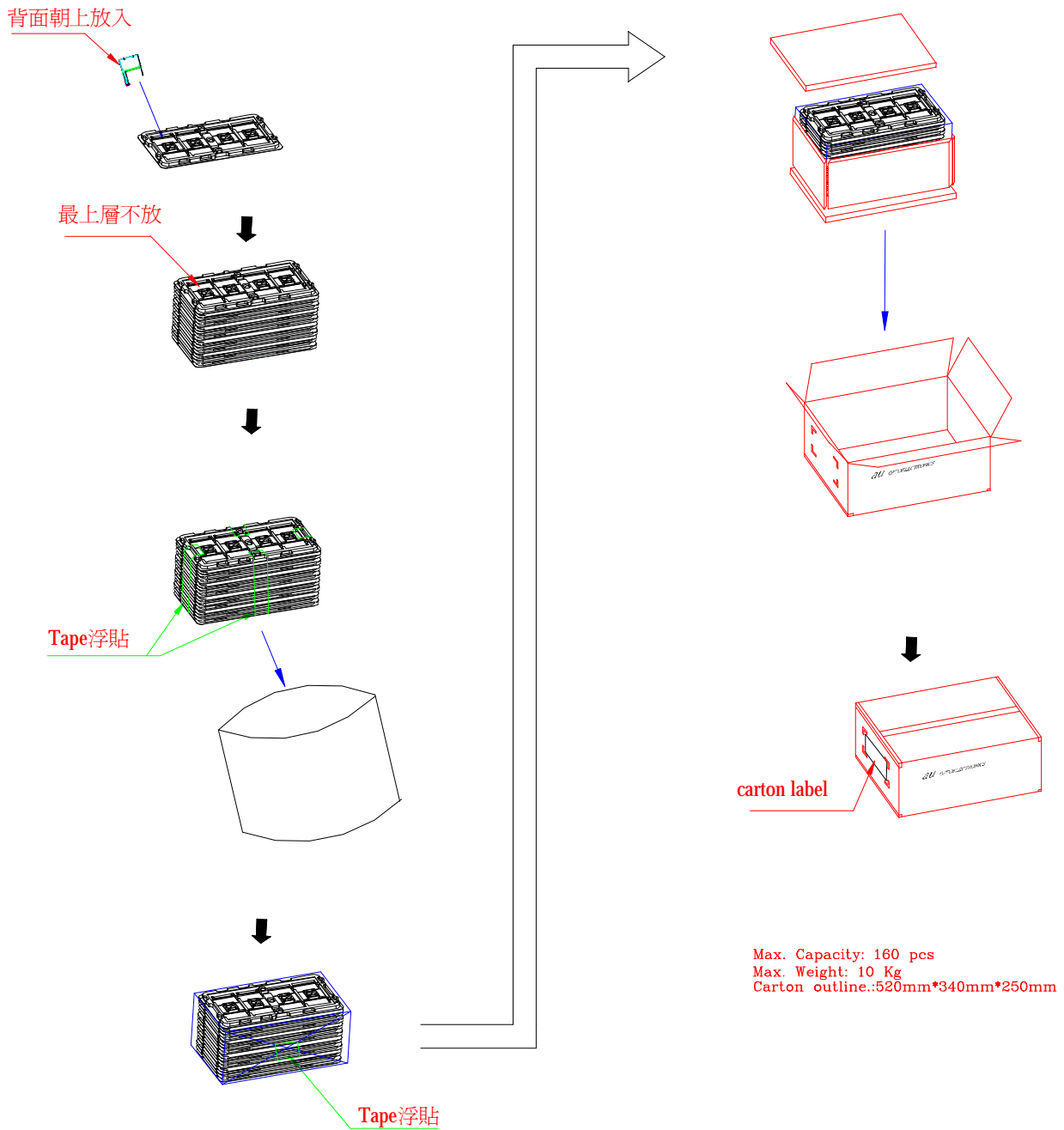

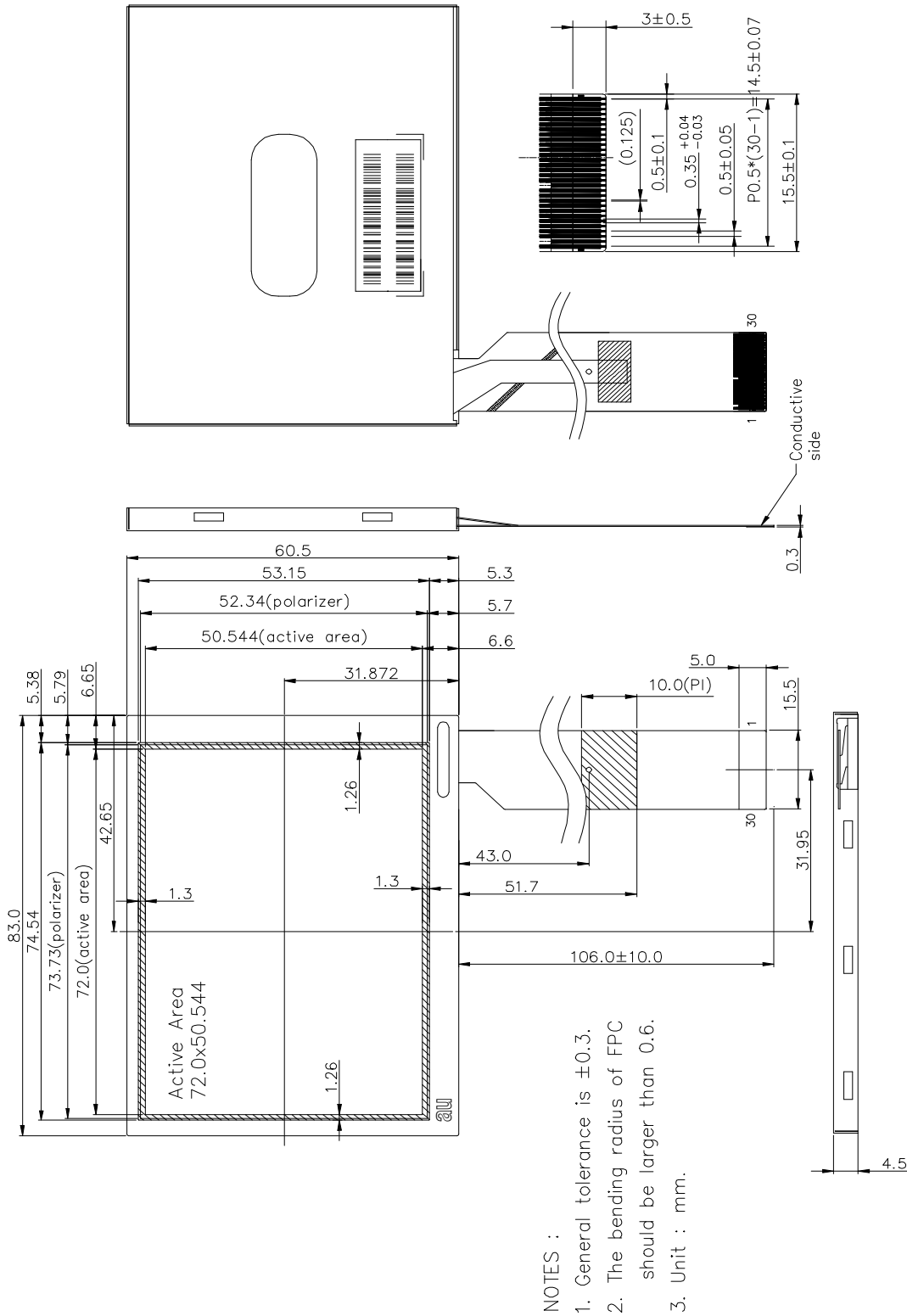

Fig.1 Outline dimension of TFT-LCD module

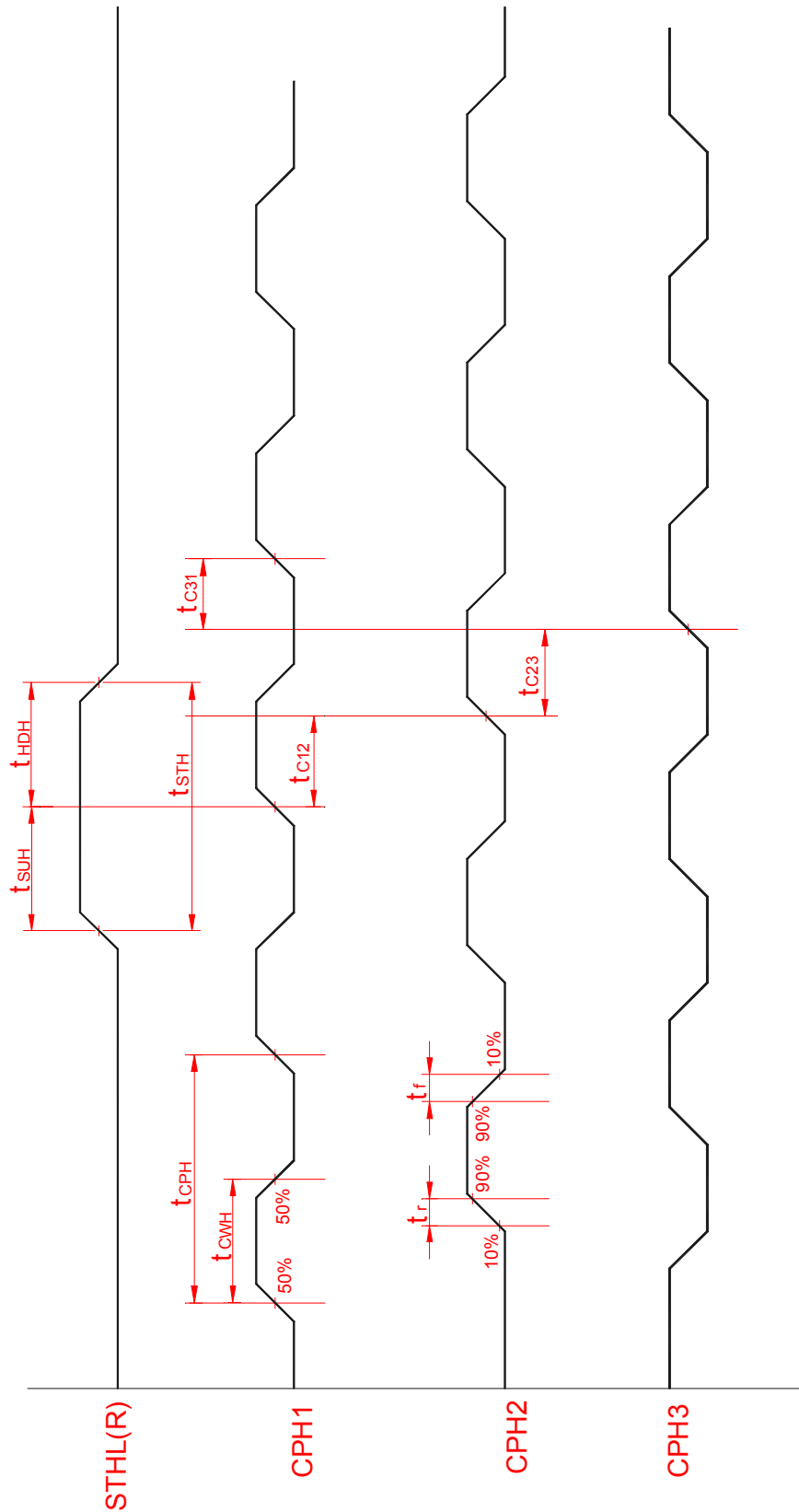

Fig.2 Sampling clock timing

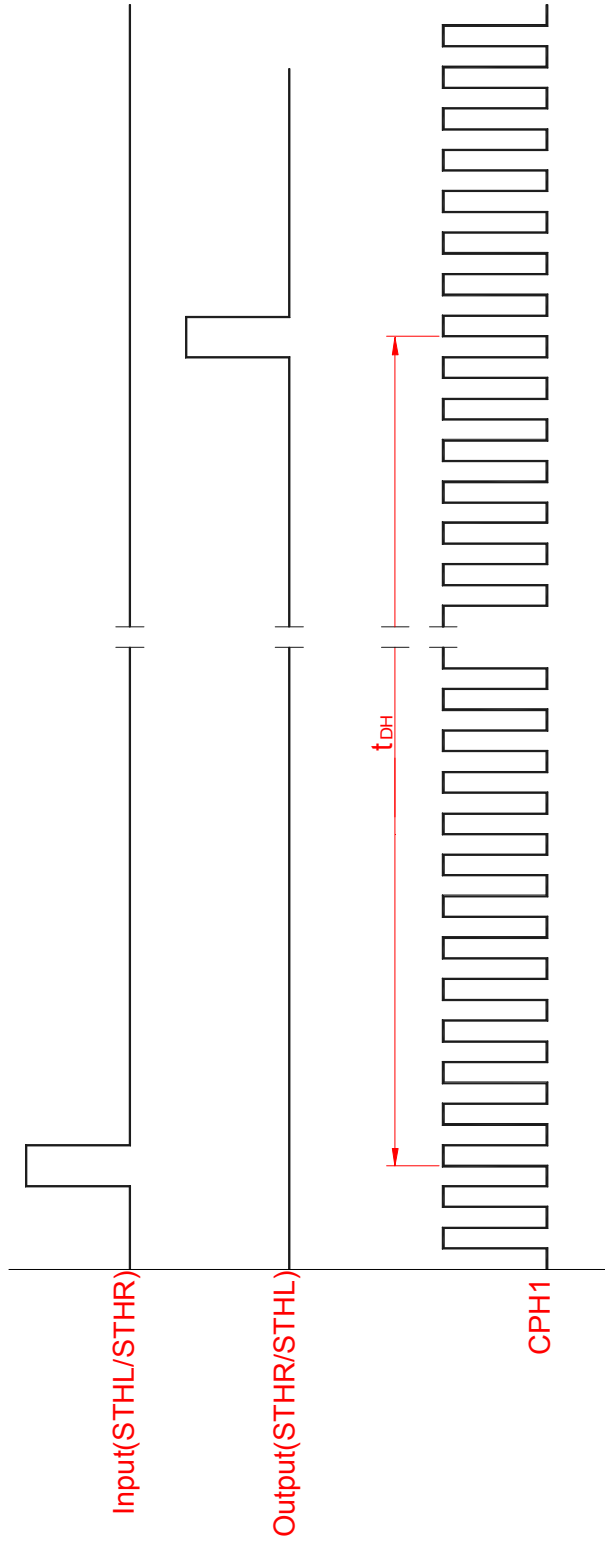

Fig.3 Horizontal display timing range

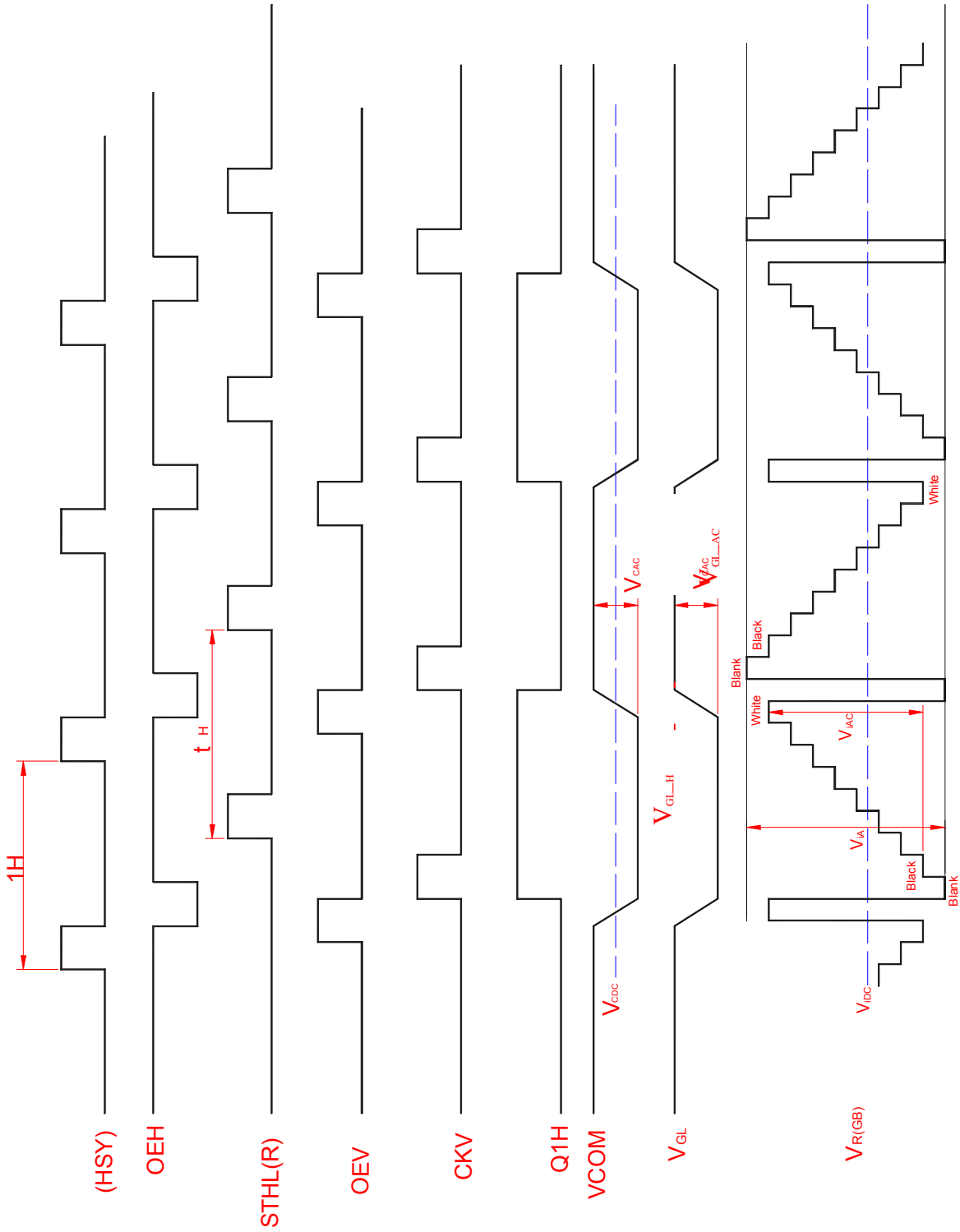

Fig.4(a) Horizontal timing

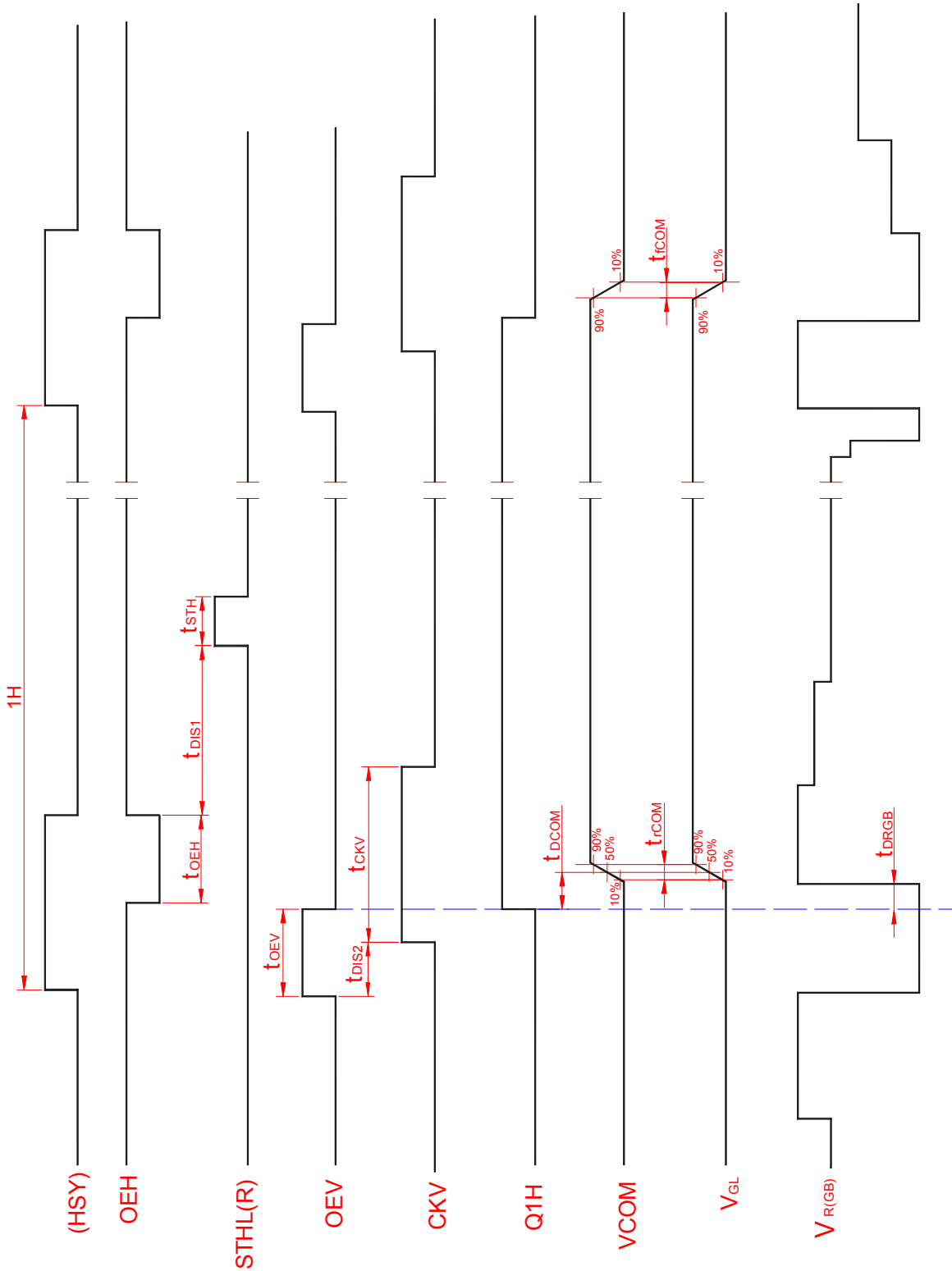

Fig.4-(b) Detail horizontal timing

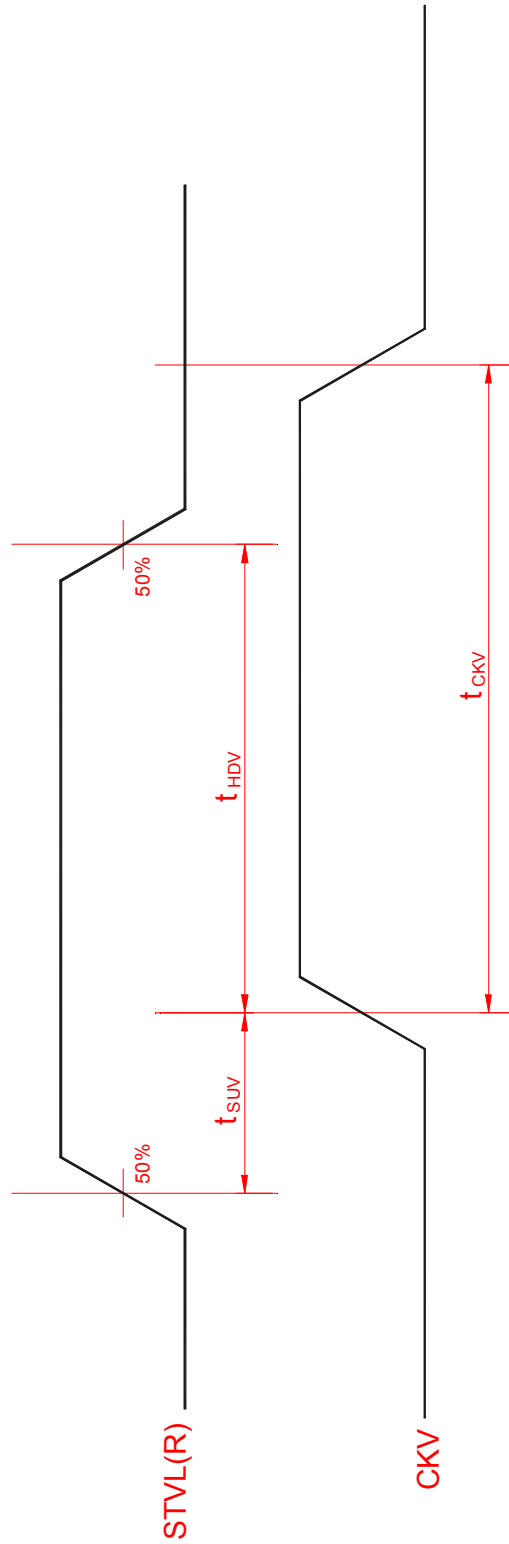

Fig.5 Vertical shift clock timing

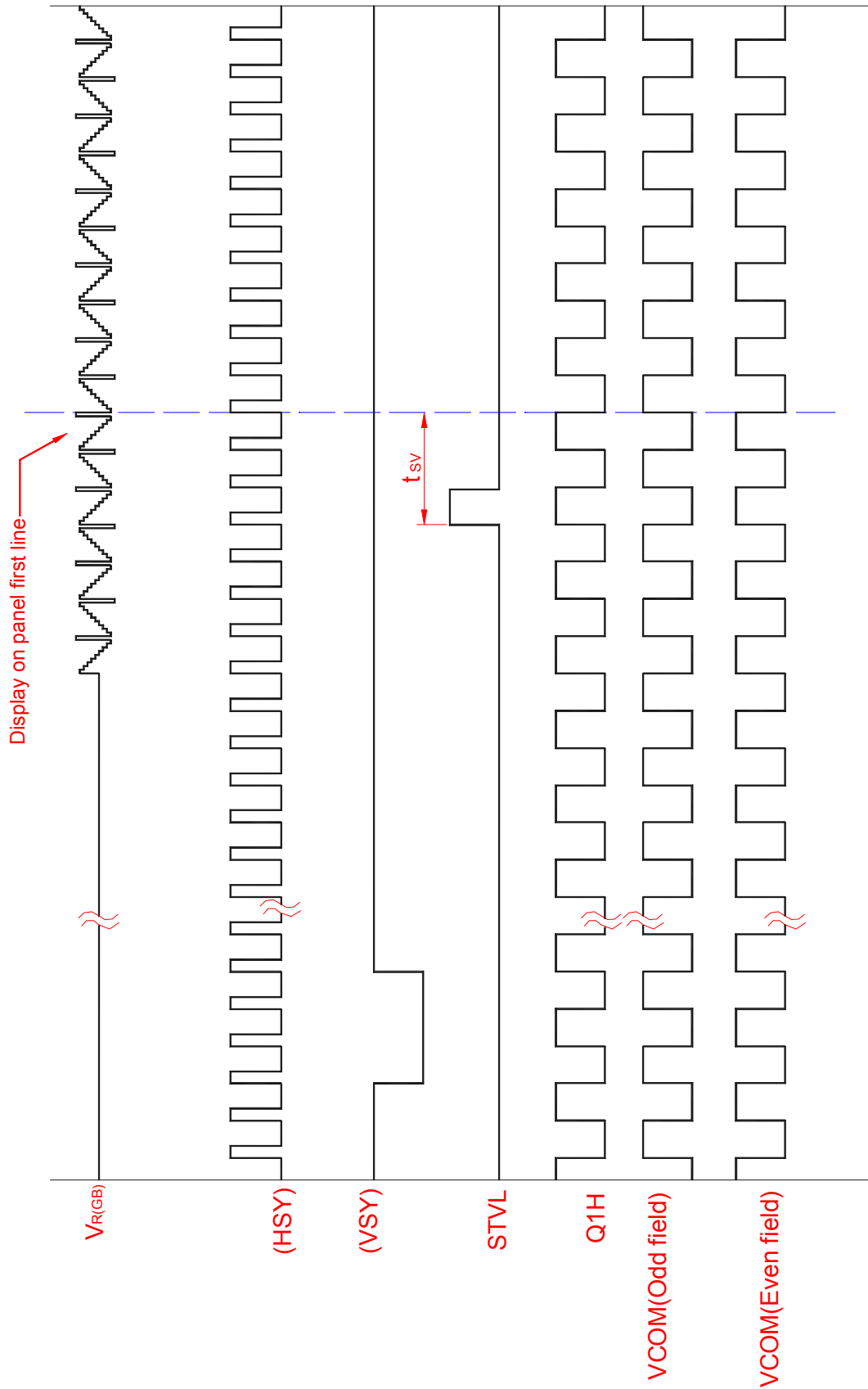

Fig.6-(a) Vertical timing (From up to down)

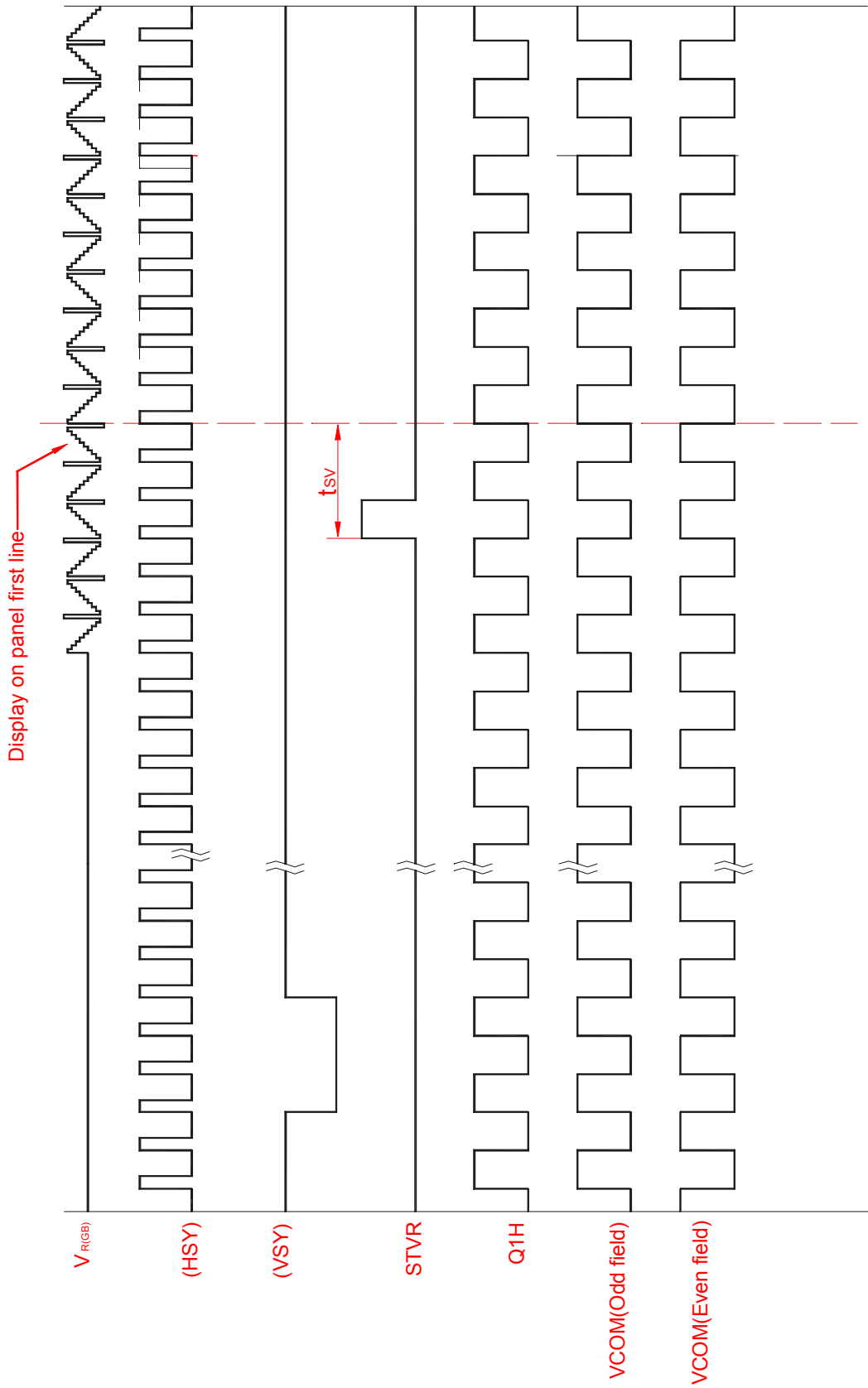

Fig.6-(b) Vertical timing (From down to up)